



[noiselimiters.co.uk](http://noiselimiters.co.uk)  
Lime Technologies

*SENTRY*  
*MK2*

*USERS MANUAL*

# Sentry MK 2

## ENVIRONMENTAL NOISE CONTROL SYSTEM

### INSTALLATION INFORMATION

#### MK2

The Sentry MK2 basically performs the same functions as the original Formula Sound Sentry but with added features and options.

- New case design provides easier connections via cable entry knock-outs and screw terminals
- A choice of internal microphone (supplied factory fitted as standard) or external microphone may be selected
- Removable cover provides access to all connectors and settings. Anti-tamper seals are provided.
- Anti-tamper microphone circuitry is incorporated with a front panel indicator.
- Dual mains voltage operation is standard (internally switchable)

#### General Detail

The Sentry was designed to help solve some of the environmental noise problems encountered at entertainment venues and in working areas.

The unit was designed to be as versatile in use as possible and features a large bar graph display. Although its main application is to control mains power outlets in entertainment venues it is not restricted to this application. Basically any function that can be controlled by a relay or switch can be controlled by the Sentry. These may include disconnecting loudspeakers, switching passive attenuators to reduce system volume or acting as the trigger into an active attenuator system.

The Sentry may also be used as a stand alone display unit indicating sound pressure levels or in industrial applications to switch on warning lamps or illuminated signs advising the use of ear defenders when the safe noise level is exceeded.

It is microphone driven and has its own built in microphone.

The Sentry incorporates the facility to operate at two different sound level thresholds which may be selected manually by a remote key switch or similar, or automatically by a time switch. (Switches not supplied)

The Sentry is provided with connectors to interface with a range of equipment, plus internally selectable options to make the system as versatile as possible.

Our technical department is always on hand to advise when unusual applications are encountered.

## Operation

The Sentry features a large bar-graph VU meter with 23dB range to give a visual indication of the noise level in a venue. This has the advantage over other units in that anyone can see the volume level and can see how their actions are contributing to this level. While the meter is operating in the green section, with even an occasional peak into the red, there is no cause for concern. The Sentry will operate within the range 80dB - 120dB and may be pre-set to anywhere in this range. Provision is included to operate at 2 different levels, for instance at different times of day. This selection can be performed manually or automatically by a time switch. A front panel indicator shows when level 2 is selected.

If a mains warning lamp is connected it will operate at the same point as the two red sections of the meter. These are labelled "WARNING".

If the noise level is high enough to light the "OVER LIMIT" section of the meter (three red sections) the noise has exceeded the allowable limit. If this is allowed to continue for more than the set time period the unit will trip and remove the power to the contactor or relay. Visual indication of this is provided above the reset button.

When the unit is first powered up the RESET indicator will be lit - wait for a few seconds and press the re-set button. The Sentry will now be re-set and ready for normal operation.

The action of the timing circuit means that continually exceeding the limit even for short periods may eventually trip the unit.

The unit has to be manually reset to restore power and this will only be possible after a short time. The reset time is determined by the amount by which the unit is driven over limit. e.g. tripping the unit by just exceeding the limit will result in a short period of a few seconds before reset is possible. Tripping the unit by grossly exceeding the limit will require a longer period before reset is possible.

**NOTE. It is important that a check is made before the unit is re-set.  
Check that it is safe to do so.**

Audio systems generally need to be powered up in a specific order. In an audio system comprising of different components amplifiers, mixers, etc. a general rule is to switch power amplifiers off first and on last to avoid possible loudspeaker damage. Therefore a band or D.J. may need to turn off amplification equipment to protect loudspeakers before the power is restored.

## Mic Tamper

An anti-tamper circuit is incorporated which if enabled will detect the presence of tape etc. placed on the case above the internal microphone in an attempt to artificially raise the internally set threshold. To enable this function adjust the T.S. preset (X) on Drg 879. (turn the pre-set to approx the 11 o'clock position. External microphones being disconnected will also be detected by a separate circuit. A front panel indicator will show MIC TAMPER.

The Sentry will switch off if the Mic tamper or Security loop indicators are illuminated.

All connections and adjustments are located beneath the removable cover plate. None reusable security labels are supplied with each unit to help ensure that unauthorised tampering is detected.

## Timer

The period of time that noise "over limit" is tolerated before the unit trips out is variable over the range of 10 - 70 seconds. A pre-set is provided to adjust this should it be necessary - the factory setting is approx. 20 seconds.

## Mounting Position

The Sentry should be mounted on a flat **solid** surface preferably where it can be seen by the persons affected by its use (D.J., band, etc.). It should be located in a position where it cannot be tampered with, e.g. a minimum of 8 feet (2.5 meters) from the floor, ideally on a wall facing the noise source. It is not necessary to have a microphone suspended above the band or dance floor. If the Sentry can hear the noise source above the background noise the unit can be calibrated accordingly.

Avoid positions that are too close to the noise source e.g. in a typical concert room with the stage area at one end the Sentry should be positioned centrally away from the stage at a **minimum** distance equal to the stage width. If there is more than one source of noise, e.g. several instruments in a band the Sentry should ideally be at a position equal distance from each instrument. (see Fig1)

### Ideal Position

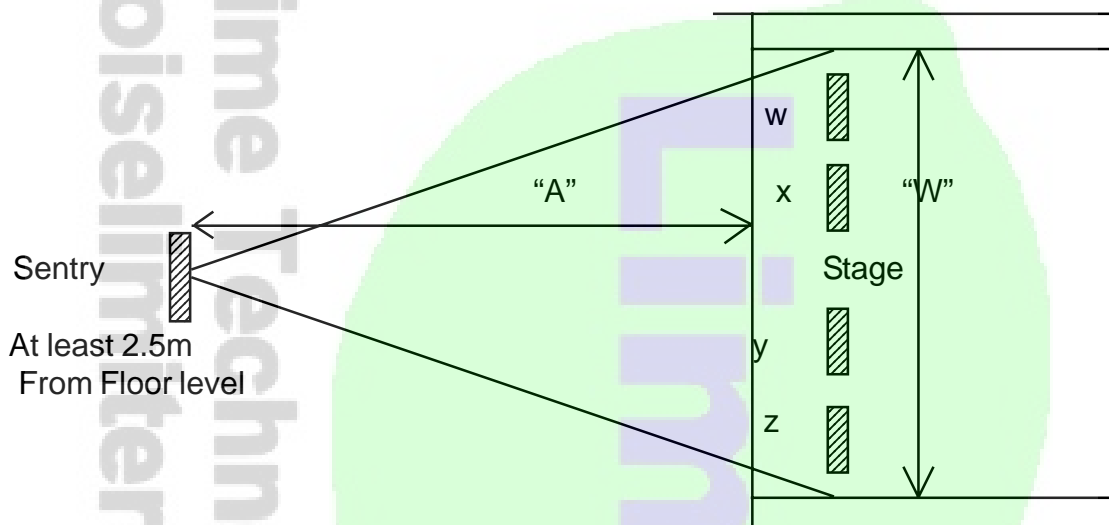

Fig 1

Distance "A" should never be less than distance "W".

### Poor Positioning

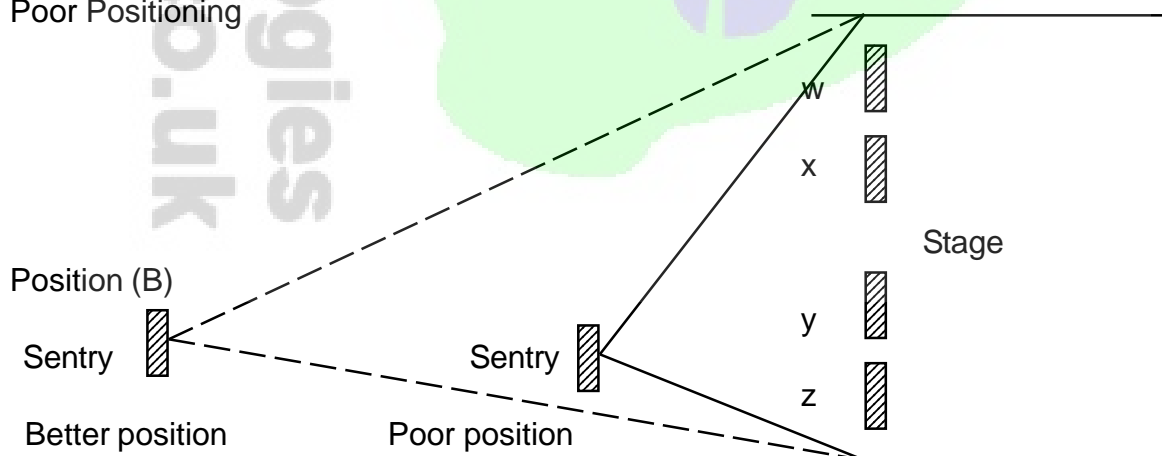

Fig 2

In Fig 2 the instruments y&z will appear louder to the Sentry than instruments w&x. Moving the Sentry back away from the stage to position (B) will minimise the problem

In order to help solve difficult location problems provision is now included to connect a remote microphone to the Sentry MK2. See Drg No 879 for more details.

## **Cable Entry And Fixing**

### **Read this section fully before proceeding**

**Customising the box.** Cable entry knock outs are provided on the rear and bottom faces of the unit, using the rear cable entries can result in a very neat installation. Select the cable entry positions to be used and remove the appropriate knock outs. (A small flat blade screwdriver on the perimeter of the hole will assist prizing out the blanking plugs.) Remove any sharp edges that may damage cables or use protective grommets (not supplied)

NOTE:- Use a separate cable entry for mains connections. **Always keep low voltage cables away from mains cables and connections**

**Fastening the unit.** The unit is secured to a wall by 3 screws (not supplied). The top centre screw locates in a key hole slot on the back of the unit.

Use No. 10 or 12 screws with round heads 1.5" (38mm) minimum length. Brick or masonry walls will require drilling and plugging in the usual manner.

First remove the cover to expose the bottom mounting screw holes, these are located in the bottom corners of the case. Fit the top centre screw 30 mm down from the required top case position, leave this screw approx. 1.5mm proud of the mounting face.

The unit may now be suspended on this screw while the two bottom mounting screw positions are marked out (ensure that the unit is captive on the screw head so it cannot fall). Fit the bottom two mounting screws.

Check that the unit is secure, cannot fall, and is not loose on the screws.

In high risk areas security screws should be utilised to prevent the unit from being removed.

## **Wiring For Applications Controlling The Mains Power.**

**All mains wiring must be installed in accordance with IEE Regulations. If after reading these instructions you are not sure how to proceed you should seek help from a qualified electrician.**

### **Overview**

The Sentry provides outputs to control a contactor or relay which in turn will control the mains supply. This strategy allows the Sentry to be mounted in the most suitable position for noise measuring whilst the mains switching equipment (the relay or contactor) can be mounted in the most convenient position for switching the mains power (fuse cupboard, etc.)

(A 32amp fully fused boxed contactor with low voltage interface has been designed for use with the Sentry and is available from Formula Sound Ltd)

The extra safety and possible lower installation costs stemming from the fact that only low voltage cable is required between the Sentry and contactor at minimal current are added benefits. The Sentry also provides connections to use a mains coil contactor with a maximum coil consumption of 60VA.

## **Installation**

Select and install a suitable contactor, arranging the installation to control all the power outlets in the vicinity. (If any are left uncontrolled it will not take very long for the enterprising band or D. J. to find and use them. It is inadvisable to arrange control of only half the outlets in a venue).

In very large installations, it is a simple matter to make 1 contactor control many others of whatever current rating is required.

Connect the contactor control back to the Sentry using appropriate cable and connections depending on the type of contactor used.

## **Connections**

All connections to the Sentry are located beneath the lower removable front cover. On this cover is also mounted the reset button which connects to the printed circuit board via a 2 pin plug and may be easily disconnected. See Drg No 879 for more details.

Connect the Sentry to a suitable mains outlet using the terminals labelled "Mains In" and ensure that the earth is also connected. The mains consumption is approximately 1amp at 240V - a 5amp lighting feed could be utilised. Connect via an isolating switch or removable plug socket arrangement so that the unit can be isolated when necessary.

For use on 120V the consumption will be approximately 2amps

**ENSURE THAT THE MAINS SUPPLY IS NOT THE SAME AS THAT CONTROLLED BY THE CONTACTOR. REMEMBER THIS SUPPLY CONTROLS ALL THE POWER OUTLETS CONTROLLED BY THE CONTACTOR.**

## **Warning Lamp**

Provision to switch a mains warning lamp to a maximum of 60VA is provided. The lamp can be of any style considered suitable but must have a maximum consumption of 60VA (60 watts). It is connected to the mains outlet terminals labelled "warning lamp". Alternatively a relay or contactor may be used to switch other lamps as required. Good wiring practice should be observed.

## **Remote Reset**

Provision for a remote reset button is provided and if this facility is required a momentary action push button or key switch should be fitted. Site this in a Manager's office or suitable location. (See separate drawing (Drg No 879) giving full connection details).

## **Setting The Permissible Volume Level**

Adjustment of allowable noise level is made by adjusting the pre-sets ADJ 1 and ADJ 2. These are located beneath the removable cover at the left hand end of the unit. They are 10-turn pre-sets to provide fine adjustment. ADJ1 sets the normal operating level, ADJ 2 sets the level for a second threshold which can be initiated remotely. An indicator on the front panel will show when level 2 is selected. Take care when making adjustments and use a small screw driver. Try to make adjustments when the noise level is displayed on the bar graph meter as you will be able to see the changes displayed on the meter.

The adjustment pre-sets have a slipping clutch at the end of travel to prevent damage. But this can cause confusion if the pre-set is at the end of travel as it then appears to do nothing (this is not usually a problem once you know about it).

## **Setting The Permissible Volume Level continued**

The actual sound pressure level (SPL) at which the unit operates can only be determined by measuring the noise level using a calibrated sound pressure level meter and adjusting the unit accordingly.

Alternatively the unit may be adjusted using trial and error but this should be used only as a temporary measure or last resort. Measuring the sound level and setting to a limit agreed with the local area official is the only recommended method.

An internal measuring microphone is fitted which will be suitable for most applications but should the need arise an external microphone can be connected. The external microphone may be a moving coil type, capacitor or electret. Microphone phantom power is provided and may be selected as required. Select a microphone with the required frequency response and polar response. (Please telephone our technical department if help is required).

NOTES:- If the unit is to be used in an entertainment venue to control a band or disco use a meter with either a linear scale or 'C' weighting response.

The frequency response of the measuring circuit of the Sentry may be selected to be, Linear (Flat response), 'C' (Conventional "C" scale) or Bass (LP filter @300Hz 12dB per octave slope.)  
See Drg No 879

'A' weighting is a frequency response curve that resembles the human ear response. It is much more sensitive in the mid 500Hz - 5kHz region. It is not recommended for entertainment venues as it is less sensitive to the bass regions where most problems lie. An "A" weighting filter may be fitted as a factory option if required.

**SECURITY LABELS ARE PROVIDED. THESE SHOULD BE FITTED TO COVER THE SCREW HEADS HOLDING THE REMOVABLE COVER IN PLACE AND WILL REVEAL ANY UNAUTHORISED ATTEMPT TO CHANGE THE THRESHOLDS**

ALWAYS FIT SECURITY LABELS AFTER ADJUSTMENTS HAVE BEEN MADE.  
EXTRA LABELS ARE AVAILABLE FROM FORMULA SOUND IF REQUIRED.

Remember that the acoustic characteristics of a venue will change depending on the number of people in it. Our experience has shown that it is always advisable to take readings when the venue is in use. It would be a wise precaution to allow in your costings for a site visit during opening hours to take measurements and make final adjustments.

### **Security Loop**

Provision to connect a security loop is provided. This may be required to detect open doors or windows that would impair the sound proofing of a building, etc. Magnetically operated reed switches of the type used in intruder alarms are most convenient for this application. If this facility is not required a wire link must be connected to allow the Sentry to work normally. (see Drg No 879)

A front panel indicator shows if the security loop is opened.

### **Tampering**

Correctly locating the unit out of reach is the best form of security.

If you find that you have problems with unauthorised persons tampering with the settings, **security screws are available** to replace the cover screws, a special key is also supplied for the fitting and removal of these screws. Contact FORMULA SOUND sales office for more details

## **Internal Settings**

Several optional settings are available internally. These are all shown on a separate drawing Drg No 879

### **Internal External Microphone Selection**

This is accomplished by the position of two jumper plugs on pin headers. Take care to move both jumpers and ensure that they connect correctly. The positions are shown on the P.C.B.

### **External Microphone Phantom power**

Phantom power is available for capacitor and electret microphones, two jumper plugs select in a similar manner to microphone selection. Ensure both jumpers are moved and connected correctly.

### **Weighting Selection**

The position of one jumper plug selects the response on the measuring microphone. The positions are shown on the P.C.B. Ensure that the jumper is seated correctly.

Special weighting options are possible - contact Formula Sound for further details.

### **External Microphone connection**

A 3 way terminal strip is provided for the connection of a remote microphone. The microphone should be low impedance and balanced and good quality twin screened cable should be used for the connections. Select a microphone with the desired frequency response and directional characteristics.

### **Led Indicators**

Outputs are provided for remote led indicators:- MIC TAMPER, LEVEL 2, WARNING, RESET REQUIRED. If more than two leds are to be connected they share a common terminal. Led current limiting resistors are not required. Leds may be connected directly. These outputs are also sufficient to drive a contactor with low voltage interface if required.

### **Timer Adjustment**

The period of time that noise "over limit" is tolerated before the unit trips out is variable over the range of 10 - 70 seconds. If adjustment is required locate the timer pre-set from Drg No 879 and adjust with a small terminal screwdriver as required. Due to the action of the circuit you may have to wait up to 70 seconds for the timing capacitor to discharge before new timer settings will take place.

Lime Technologies

UK

Web: [noiselimiters.co.uk](http://noiselimiters.co.uk)

Email: [service@noiselimiters.co.uk](mailto:service@noiselimiters.co.uk)

DISCONNECT POWER BEFORE REMOVING COVER.

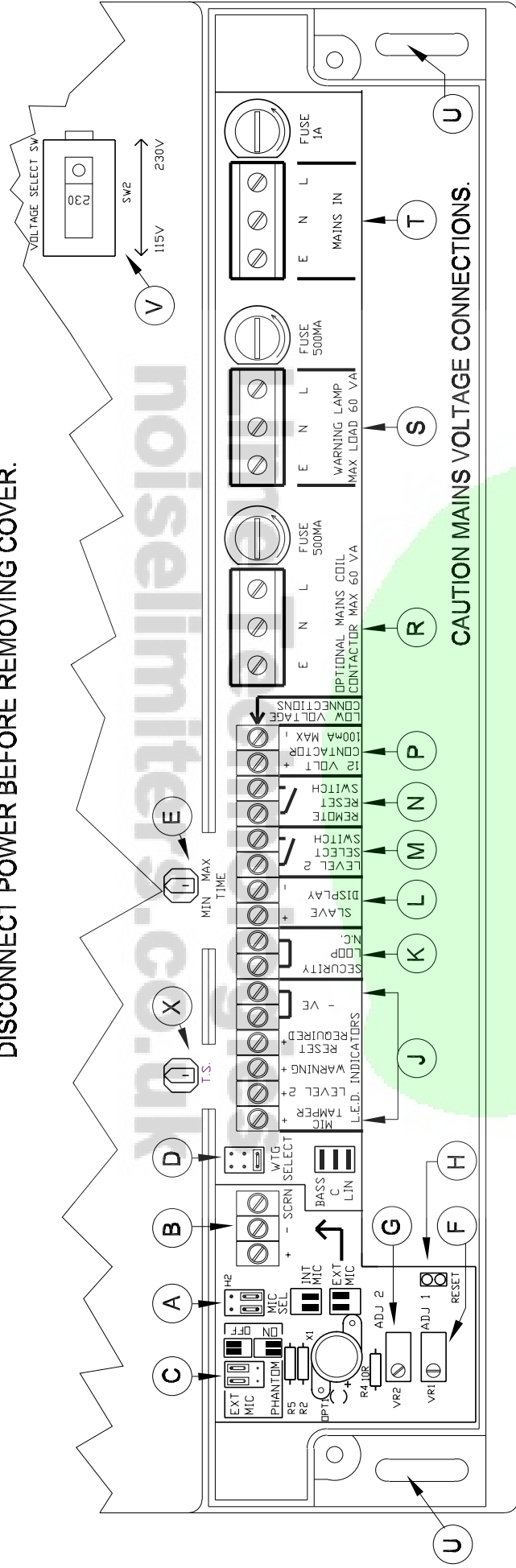

- A. Internal, External. Measuring microphone selection.
- B. External measuring microphone connection terminals.
- C. Phantom power selector for external microphone.
- D. Weighting response selector. (measuring microphone)
- E. Timer adjustment pre-set.
- F. Level 1 (normal) adjustment pre-set.
- G. Level 2 adjustment pre-set. (see M. to select)
- H. Reset switch connector
- J. Terminals for the connection of external Led indicators etc.
- K. Security loop connection. Link if not used.
- L. Output for a Slave Display.
- M. Terminals to connect level 2 selector switch.
- N. Terminals to connect remote reset switch.
- P. Terminals to connect low voltage contactor.
- R. Terminals to connect mains coil contactor.
- S. Terminals for the connection of a mains warning lamp 60 Watts Max
- T. Mains Input Terminals
- V. Voltage selector. (Slide switch)
- U. Bottom mounting holes.
- X. Internal microphone tamper sensitivity adjustment



TITLE SENTRY MK2

DETAILS OF TERMINALS AND OPTIONS

DRG No. 879

LOCATED BENEATH REMOVABLE COVER.

DATE 20-03-2003

ISSUE 3

## FUSE: 10.3mm HRC Type gI 32Amp

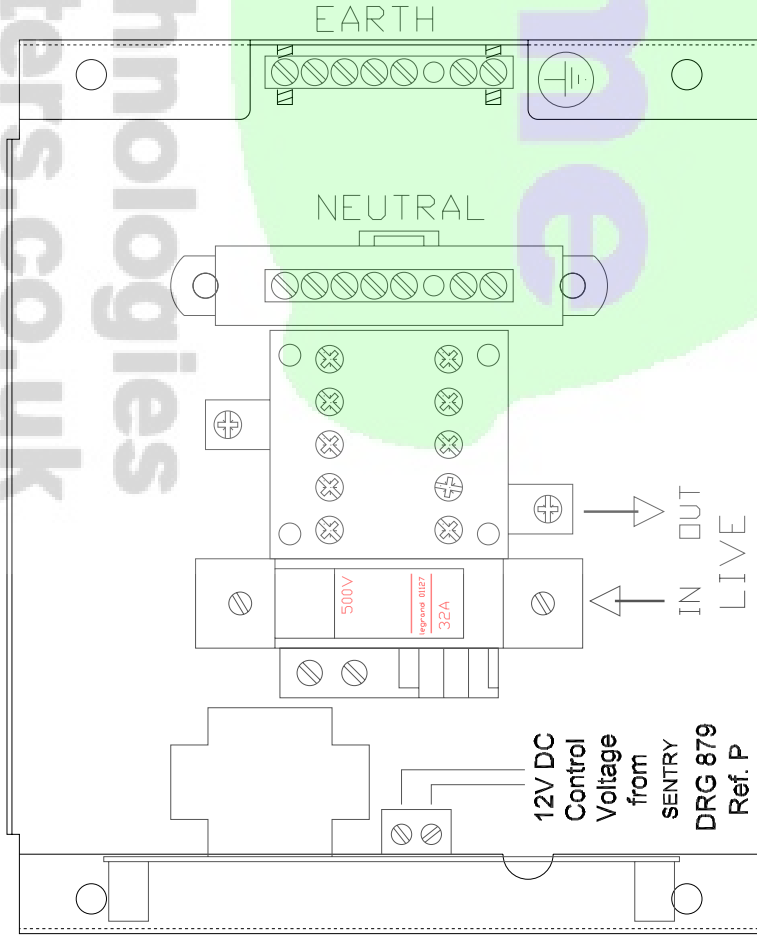

The SENTRY is capable of driving several low voltage controlled Contactors simply connect each contactor to the SENTRY in parallel. The Polarity is not critical

**DISCONNECT POWER BEFORE REMOVING COVER**

**THIS UNIT SHOULD ONLY BE INSTALLED  
& MAINTAINED BY A SUITABLY QUALIFIED PERSON**

**THIS EQUIPMENT MUST BE EARTHED.**

**TO ENSURE SAFE OPERATION OF THIS UNIT AND THE EQUIPMENT CONNECTED TO IT READ THE FOLLOWING AND TAKE THE APPROPRIATE ACTION.**

Installation and connection should only be carried out by a suitably qualified person and in accordance with local wiring regulations. In the UK strict adherence to BS7671 (IEE Regulations) is essential. All low voltage wiring should be segregated from mains voltage wiring, unless cables are adequately insulated.

The unit should be connected to a single phase supply of nominally 220-240Vac. The fuse fitted is a 10mm x 38mm gI type of 32A rating, a lower current rated fuse may be fitted if required.

If a fuse needs replacing ensure the type, size & rating is correct. In the event of fuse failure, investigate the cause of failure before replacing the fuse. **POWER SHOULD BE DISCONNECTED WHILE FUSES ARE CHECKED OR REPLACED.**

### DESCRIPTION

This unit is essentially a single pole normally open switch. It allows a low voltage (nominally 12V) to control up to 32amps of mains power. The control voltage should be 12V dc. It is designed for European single phase supplies nominally 220-240Vac. The unit has an internal fuse to protect the contactor & outgoing cabling.

The unit should not be used free standing, it must be securely fixed before use. It is only suitable for use indoors. The unit should not be installed in an atmosphere subject to high humidity, high temperatures or excessive pollution. These units are not designed for use in a domestic environment

### INSTALLATION

1. Remove lid of unit by removing the four screws & pull off the lid earthing connector
2. Decide on fixing position & the required 20mm conduit entries. The side entries are conventional knockouts, the base entries are plugged with plastic bushes which can be levered out with a screwdriver. There are two small diameter plugged holes on the left hand side, which may be useful for the low voltage control cable. Grommets are included to bush any holes that are used.
3. The box should be fixed to a suitable surface using the four base mounting holes. A template is included to assist in fixing.
4. Make electrical connections to the unit referring to the drawing. A suitable means of isolating the unit should be provided to allow any maintenance to be undertaken safely.
5. ENSURE THAT THERE IS ADEQUATE SEPARATION BETWEEN LOW VOLTAGE CABLES AND MAINS WIRING.
6. Reconnect the lid earthing lead. Refit the lid and securely fasten. Test for satisfactory operation. Include all tests detailed in the wiring regulations.



TITLE **BOXED LOW VOLTAGE CONTROLLED CONTACTOR**

DRG No. 755

DATE 15-11-1999

ISSUE 2

# SENTRY MK2 ADDENDUM

## Sentry "A" weighting Option

An "A" weighting option is available for applications that require it i.e. Industrial noise applications. 'A' weighting is a frequency response curve that resembles the human ear response. It is much more sensitive in the mid 500Hz - 5kHz region. It is selected by placing the weighting response selector in the top position.

Where this option is fitted the "Bass" weighting filter is replaced by the "A" weighting filter. Sentry units supplied with this option will have been re-labelled as "A" instead of Bass on the PCB.

'C' weighting and Linear response are still available by using the weighting response selector. (See Drg. 879 Section D).

---

## REMOTE RESET SWITCHES

2 types of remote reset switch are available a push button version and a key switch version for extra security. Both types feature a surface mount box 65mm X 65mm X 45mm depth. They are fitted with led's to indicate Warning and Reset. Connections are the same for both types.

## SENTRY RESET SWITCH

### TERMINAL INFORMATION

CONNECT TO SENTRY USING SIGNAL CABLE  
CURRENT IS MINIMAL 7/0.2MM IS IDEAL  
6 CORE RS 365-587

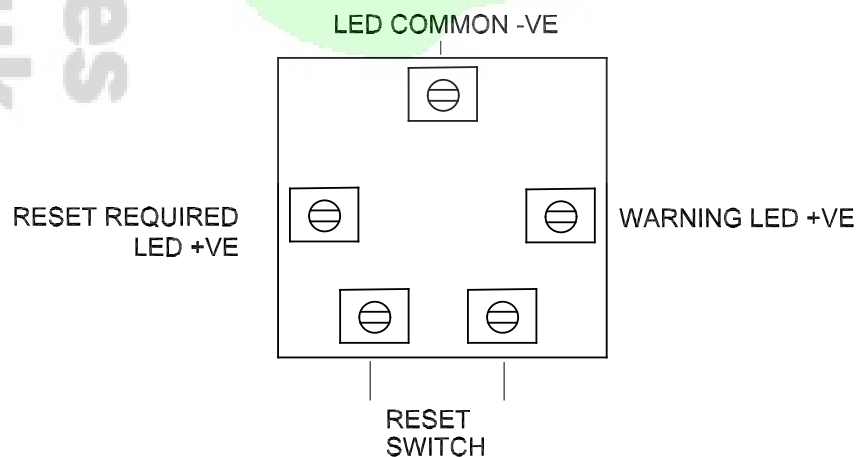

VIEW FROM TERMINAL SIDE OF P.C.B.